

**BASE**

**TOP**

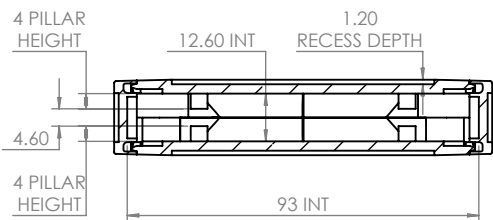
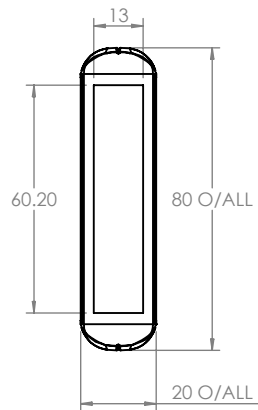
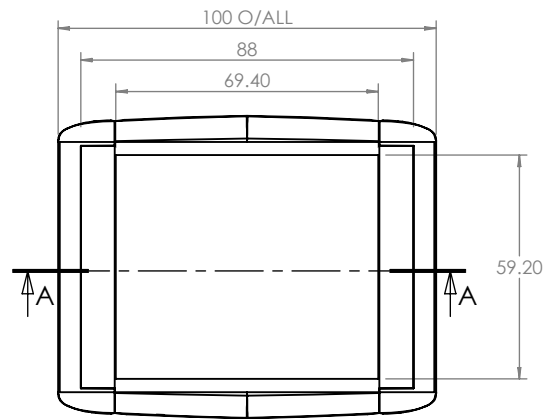

SECTION A-A

**ASSEMBLY**

**ISO VIEW  
1:3**

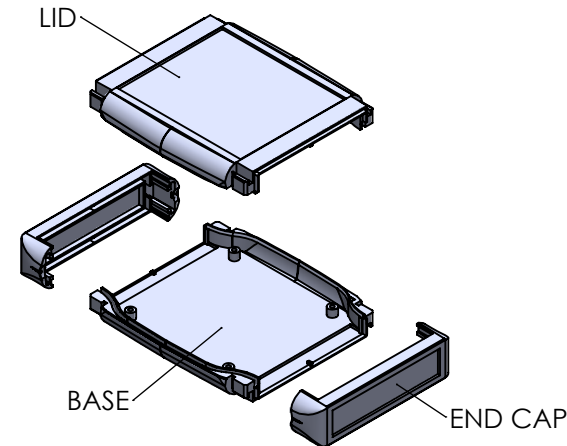

END CAP SUPPLIED SEPERATELY

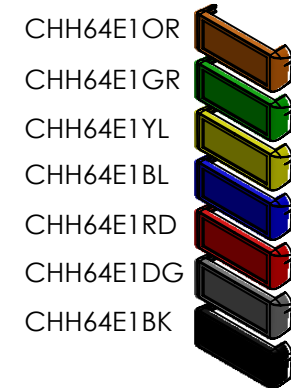

**CAMDENBOSS**  
ELECTRONICS & ENCLOSURES

JAMES CARTER RD, MILDENHALL, SUFFOLK. IP28 7DE  
TEL: 01638 716101 FAX: 01638 716554  
EMAIL: Sales@CamdenBoss.com  
WEB: www.CamdenBoss.com

UNLESS OTHERWISE SPECIFIED:  
DIMENSIONS ARE IN MILLIMETERS

GENERAL TOLERANCES +/- 0.2

FINISH:  
LIGHT SPARK

MATERIAL: UL94-V0 ABS  
GREY

PROJECTION.

DO NOT SCALE DRAWING

REVISION. 0

TITLE: GENERAL ASSEMBLY DRAWING  
FOR 64 SERIES

DWG NO.

**CHH641NGY**

A4

SCALE: 1 : 2

SHEET 1 OF 1

	NAME	SIGNED	DATE
DRAWN	JAMIE JACOBS	JNJ	24/06/13
CHK'D	-	-	-